



US006114991A

United States Patent [19]

[11] Patent Number: **6,114,991**

Richton et al.

[45] Date of Patent: **Sep. 5, 2000**

[54] **AUXILIARY SYSTEM FOR ASSISTING A WIRELESS TERMINAL IN DETERMINING ITS POSITION FROM SIGNALS TRANSMITTED FROM A NAVIGATION SATELLITE**

[75] Inventors: **Robert Ellis Richton**, Madison; **Giovanni Vannucci**, Township of Middletown, Monmouth County, both of N.J.

[73] Assignee: **Lucent Technologies, Inc.**, Murray Hill, N.J.

[21] Appl. No.: **08/927,434**

[22] Filed: **Sep. 11, 1997**

[51] Int. Cl.⁷ **H04B 7/185**

[52] U.S. Cl. **342/357.1; 342/357.05; 342/357.06; 375/200**

[58] Field of Search **342/357.1, 357.06, 342/357.09, 357.05; 701/213, 215; 375/200, 208**

[56] **References Cited**

U.S. PATENT DOCUMENTS

4,313,183	1/1982	Saylor	367/128
4,445,118	4/1984	Taylor et al.	343/357
5,515,062	5/1996	Maine et al.	342/457
5,615,173	3/1997	Brumley et al.	367/90

5,642,377	6/1997	Chung et al.	375/200
5,687,166	11/1997	Natali et al.	370/209
5,689,245	11/1997	Noreen et al.	340/825.49
5,847,678	12/1998	Tachita	342/357
5,862,172	1/1999	Sugita et al.	375/200
5,872,810	2/1999	Phillips et al.	375/222
5,912,644	6/1999	Wang	342/457

Primary Examiner—Thomas H. Tarca
Assistant Examiner—Dao L. Phan
Attorney, Agent, or Firm—DeMont & Breyer, LLC; Jason Paul DeMont; Wayne S. Breyer

[57] **ABSTRACT**

A wireless terminal and auxiliary system are disclosed that enable the wireless terminal to determine its location based on signals transmitted from navigation satellites. In particular, the tasks of signal acquisition and signal processing required of a wireless terminal in the prior art are divided between the wireless terminal and the auxiliary system in accordance with the illustrative embodiment. The auxiliary system assists the wireless terminal by acquiring information about the satellites' ephemerides, by partially processing it and by transmitting the partially processed information to the wireless terminal in a form that is useful to the wireless terminal. The wireless terminal then uses the partially processed information from the auxiliary system to assist the wireless terminal in acquiring the ranging signals from the navigation satellites quickly and when they are weak.

60 Claims, 7 Drawing Sheets

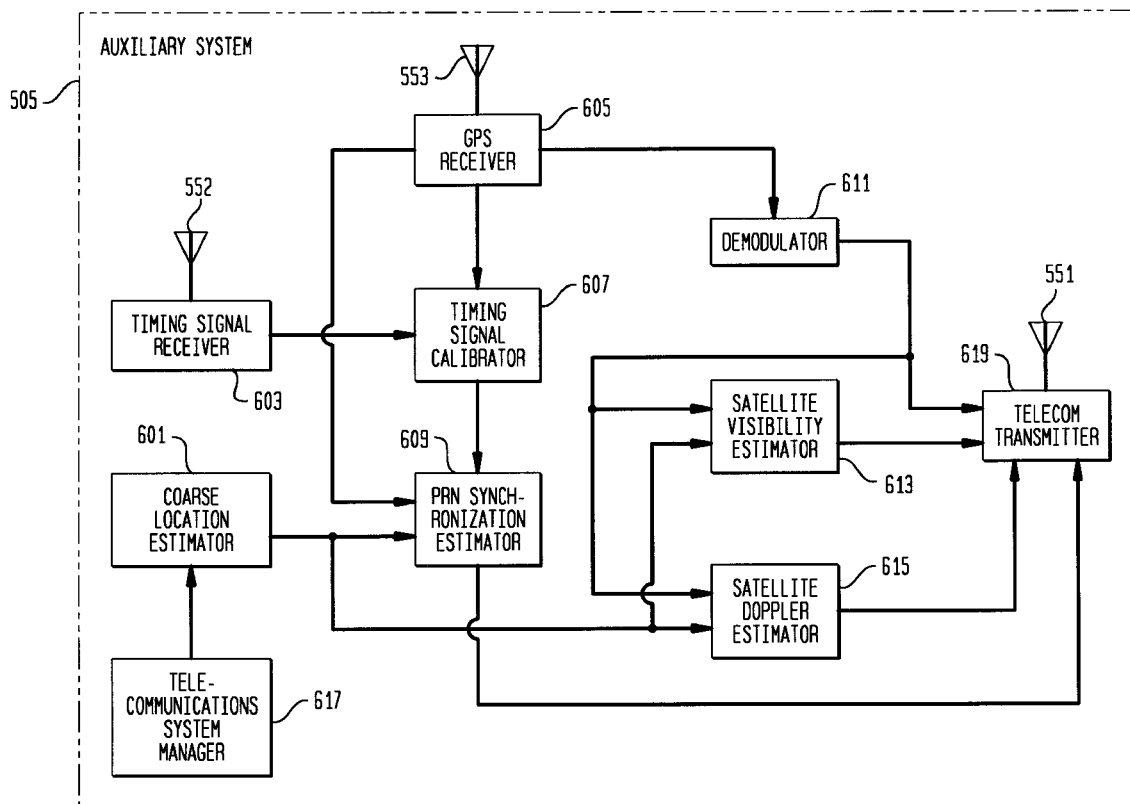

FIG. 1
(PRIOR ART)

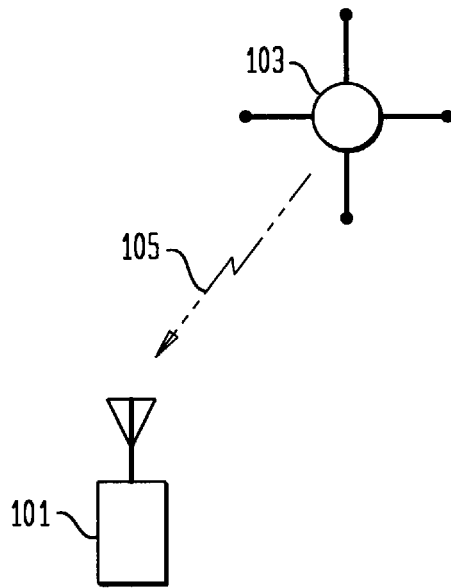

FIG. 2
(PRIOR ART)

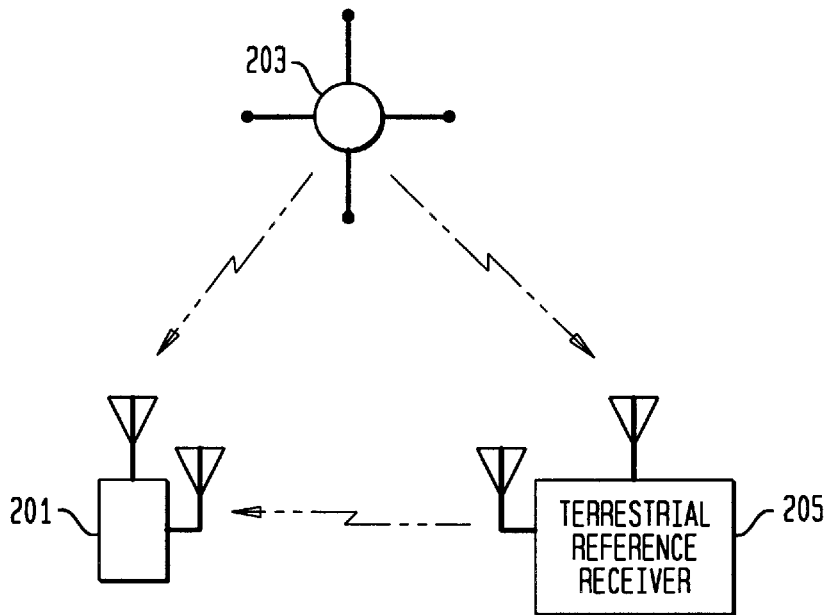

FIG. 3
(PRIOR ART)

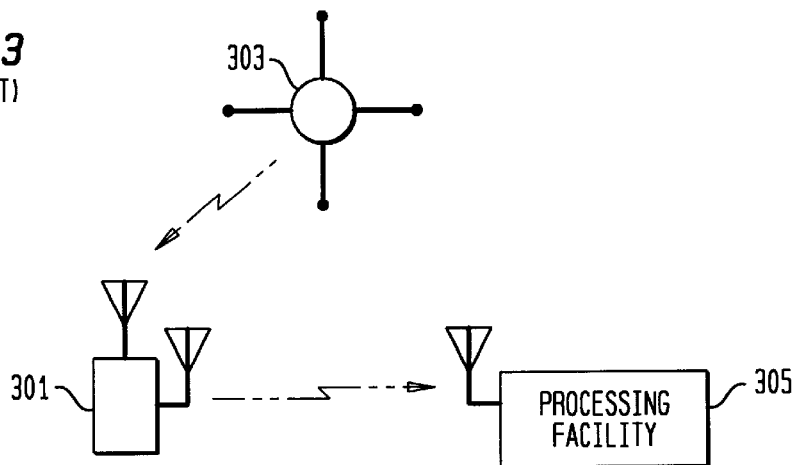

FIG. 4
(PRIOR ART)

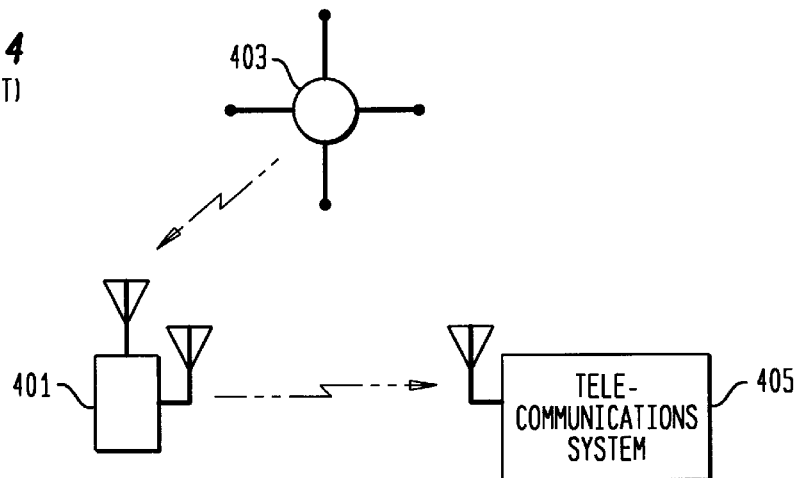
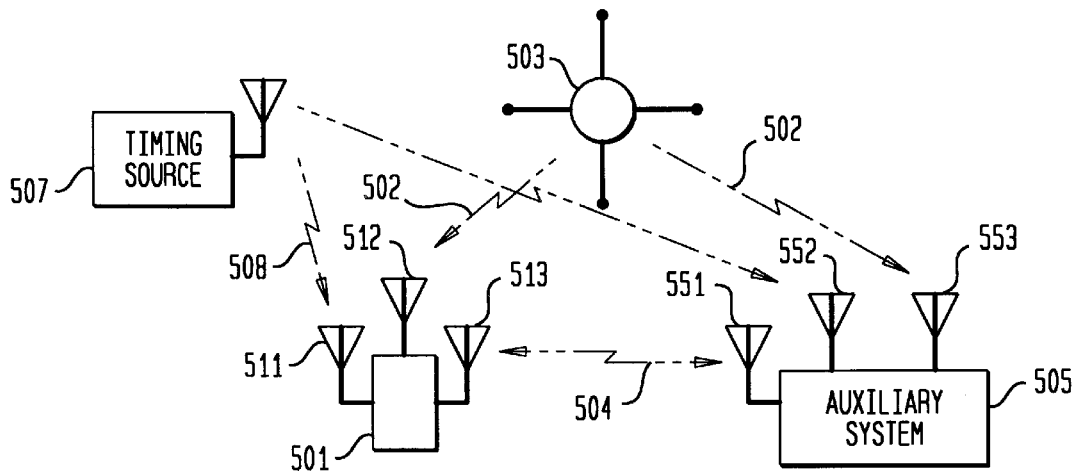

FIG. 5



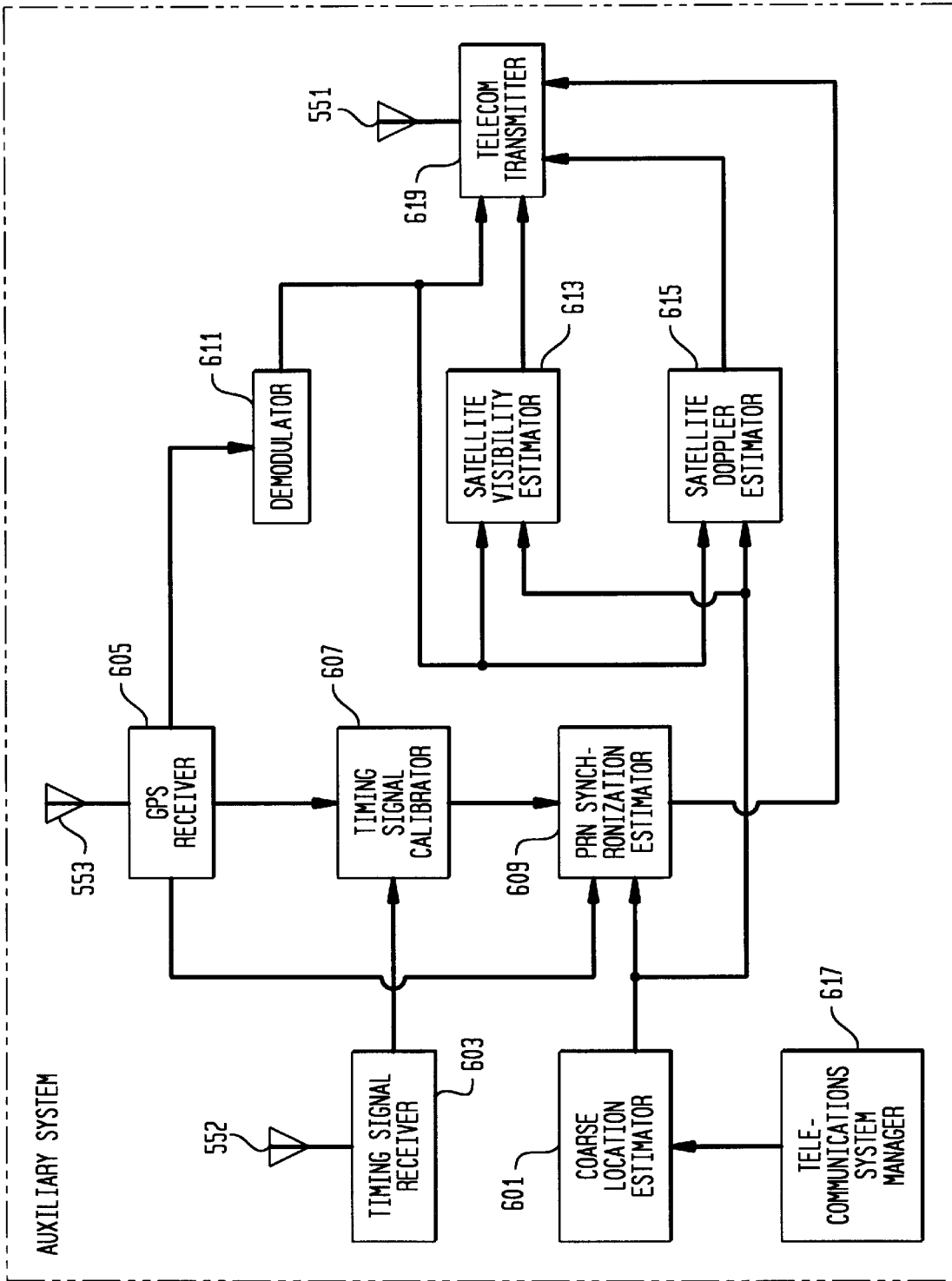

FIG. 6

505

FIG. 7

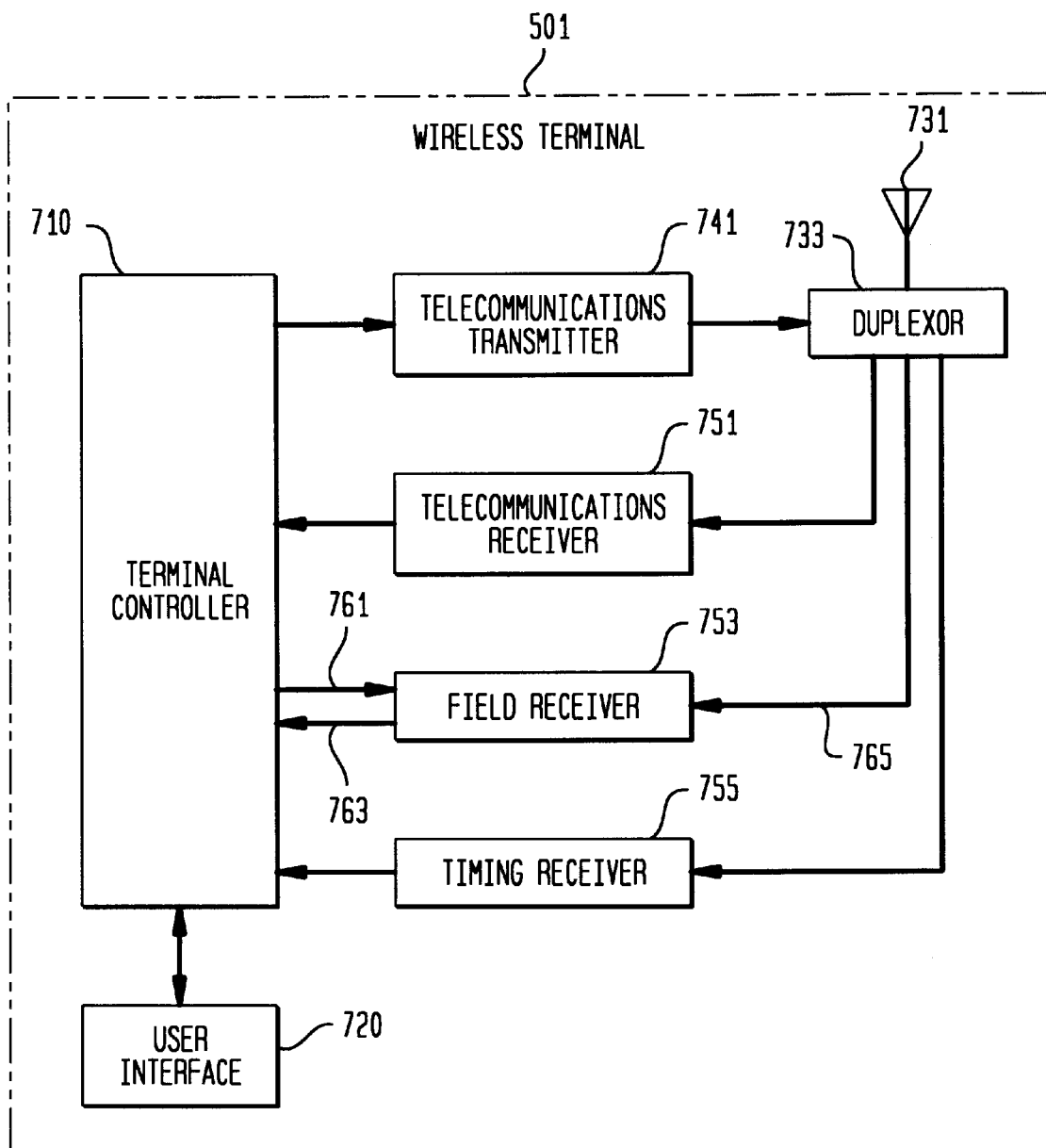

FIG. 8

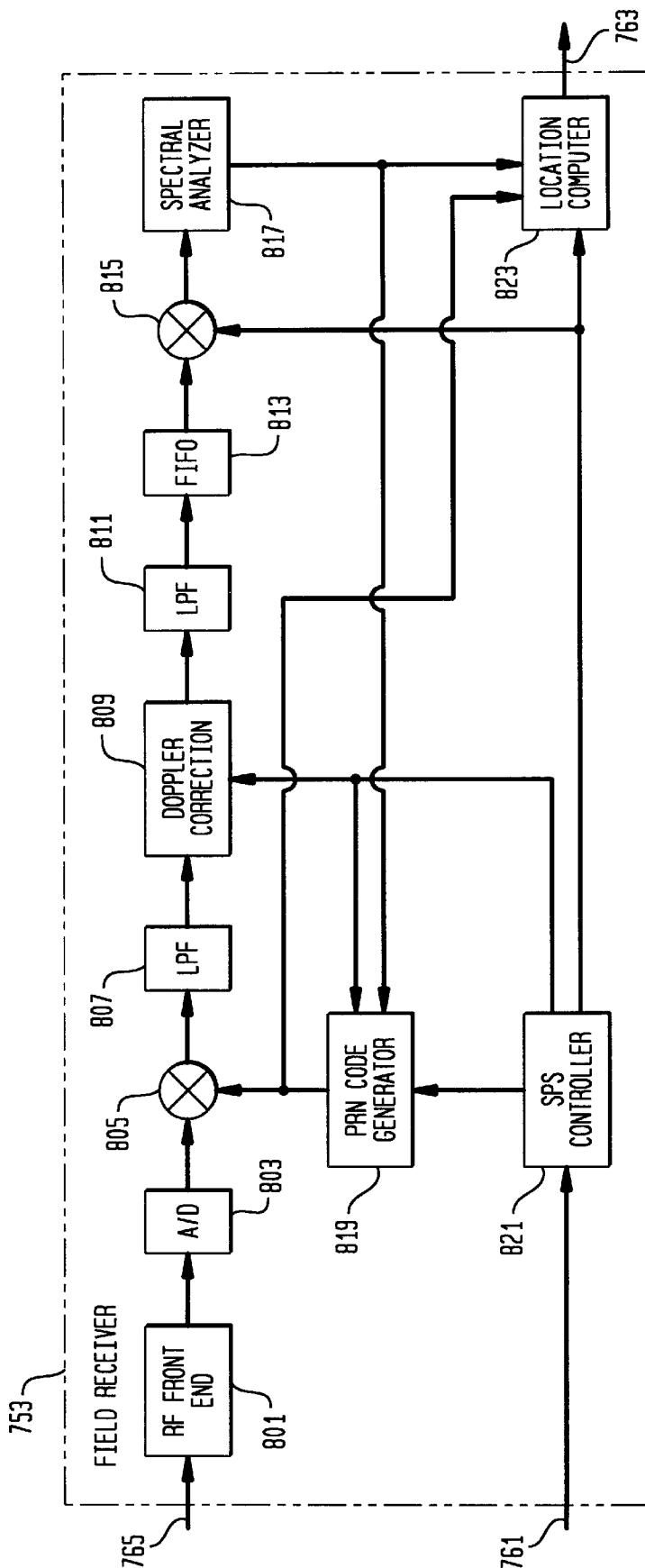

FIG. 9

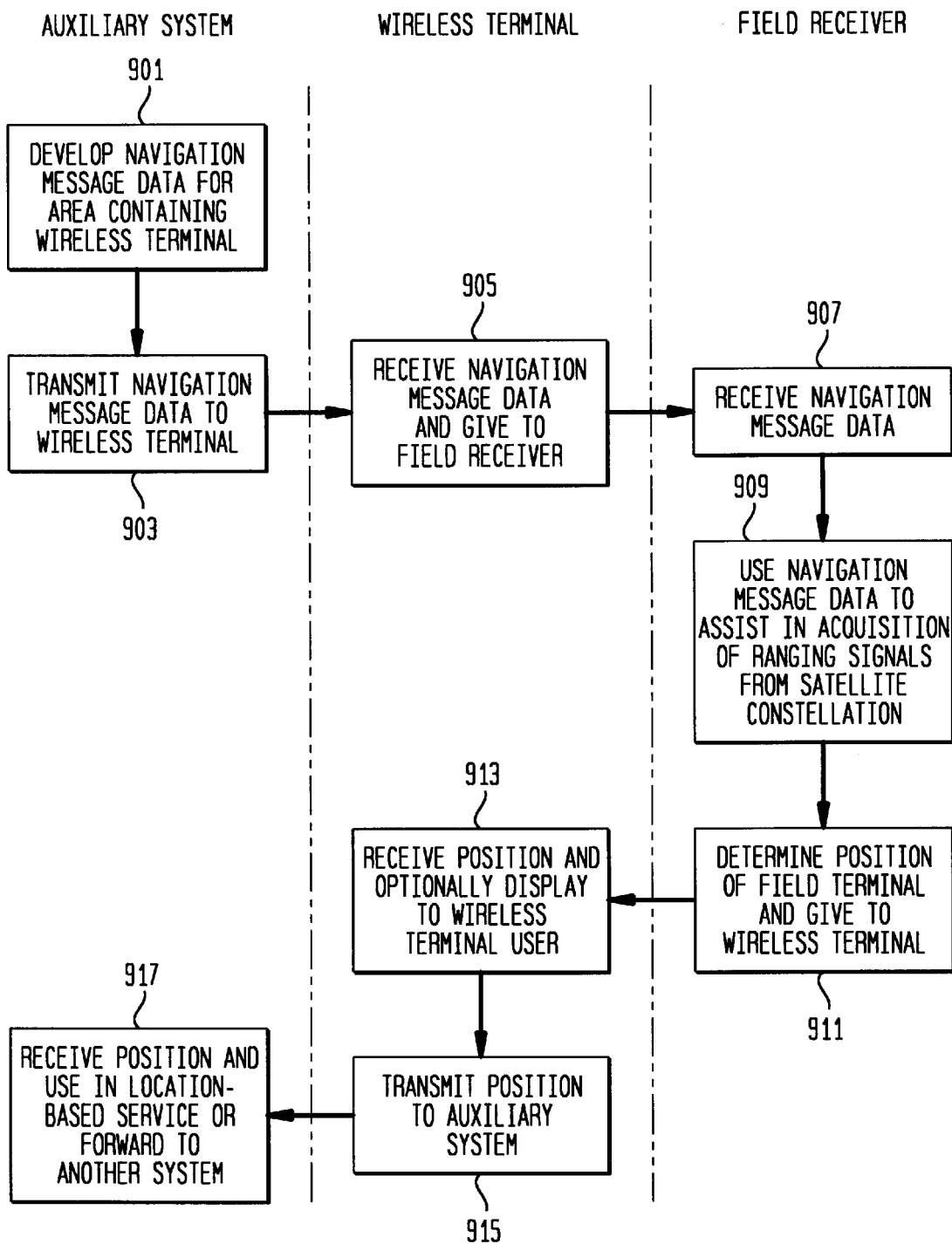
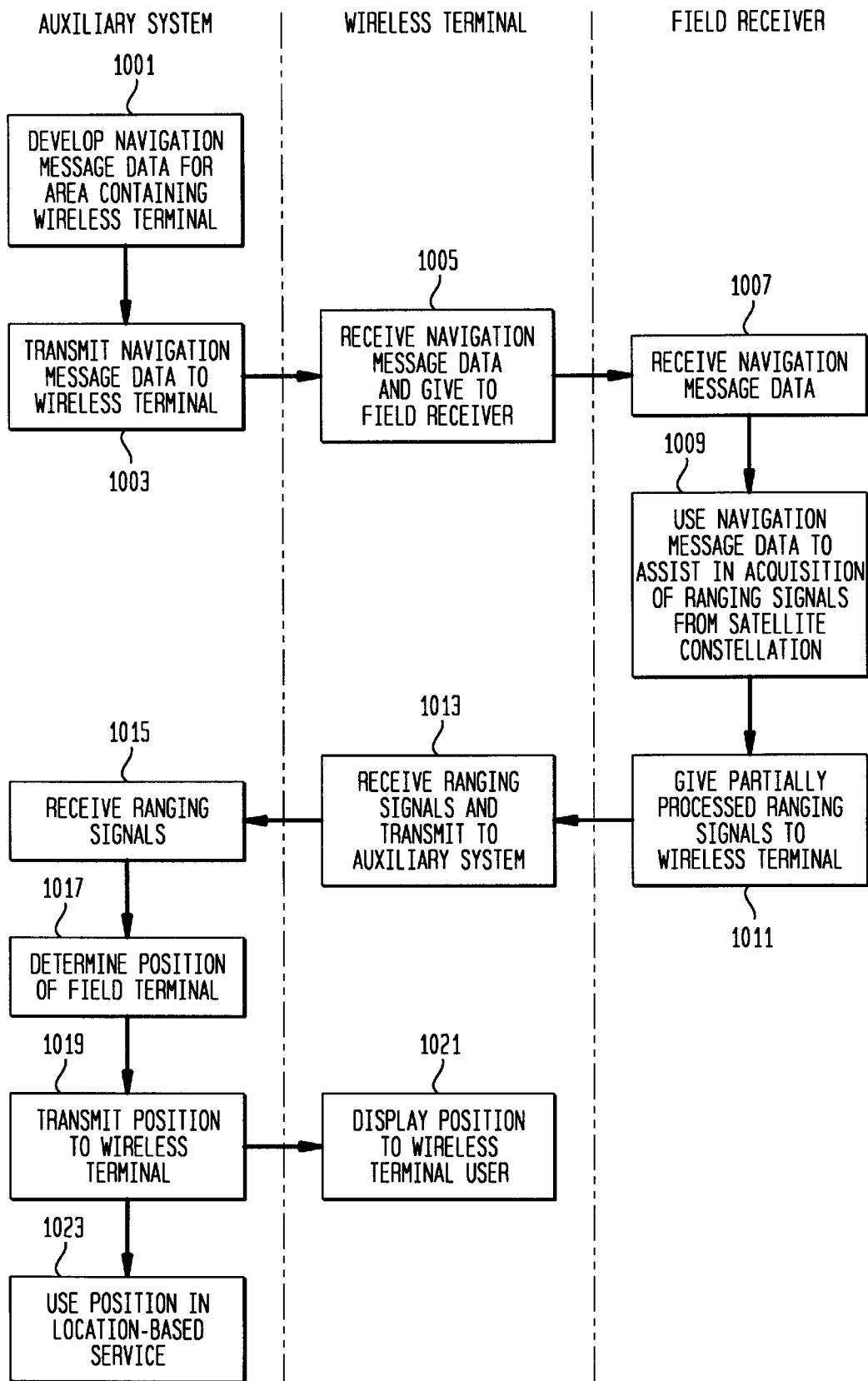

FIG. 10



**AUXILIARY SYSTEM FOR ASSISTING A
WIRELESS TERMINAL IN DETERMINING
ITS POSITION FROM SIGNALS
TRANSMITTED FROM A NAVIGATION
SATELLITE**

FIELD OF THE INVENTION

The present invention relates to satellite positioning systems in general, and, more particularly, to a telecommunications-based auxiliary system that assists a wireless terminal in determining its position from signals transmitted from one or more navigation satellites.

BACKGROUND OF THE INVENTION

A satellite positioning system, such as the Global Positioning System ("GPS"), comprises a constellation of satellites that transmit signals that can be used by a wireless terminal to determine, in well-known fashion, the wireless terminal's position. Typically, the signals transmitted by each satellite convey three types of information: (1) satellite trajectory data, (2) system timing, and (3) ranging information. When a wireless terminal can acquire the signals from three or more satellites the wireless terminal can determine its position through triangulation, as is well-known in the art. FIG. 1 depicts a schematic diagram of a satellite positioning system in the prior art.

Although a conventional wireless terminal can determine its position with some degree of accuracy, fluctuations in the ionosphere and the atmosphere and jitter in the transmitted signals themselves prevent a conventional wireless terminal from determining its position with a high degree of accuracy. To mitigate the effects of these factors and thus improve the degree of accuracy with which a wireless terminal can ascertain its position, another satellite positioning system, typified by the Differential Global Positioning System ("DGPS"), was developed. FIG. 2 depicts a schematic diagram of a Differential Global Positioning System.

As is well-known in the prior art, DGPS comprises terrestrial reference receiver 205, whose position is static and exactly known through conventional survey techniques, in addition to satellite constellation 203 and wireless terminal 201. The theory underlying DGPS is that when wireless terminal 201 is in close proximity (e.g., within 50 miles) to terrestrial reference receiver 205, both wireless terminal 201 and terrestrial reference receiver 205 are expected to experience the same ionospheric and atmospheric fluctuations and signal jitter. Terrestrial reference receiver 205 uses the signals from satellite constellation 203 to estimate its position, and, using its known exact position, calculates the error between its estimated position and its known exact position. That error or "difference" is a vector that represents the inaccuracy of the estimated position from the ionospheric and atmospheric fluctuations and signal jitter. The difference vector is broadcast by terrestrial reference receiver 205 to wireless terminal 201 in real time. When wireless terminal 201 estimates its position through conventional means, it uses the difference vector received from terrestrial reference receiver 205 to subtract out the effects of the ionospheric and atmospheric fluctuations and signal jitter.

FIG. 3 depicts a schematic diagram of a Tidget® satellite positioning system in the prior art. The wireless receiver in a Tidget system does not compute the position of the wireless terminal. Instead, the wireless receiver in a Tidget system acts like a wireless repeater in that it receives the signals from the satellite constellation and then relays the

unprocessed signals to a remote processing facility, which uses the signals to determine the position of the Tidget wireless terminal. An advantage of a Tidget system is that it reduces the cost of the wireless terminal by eliminating from the wireless terminal the expensive circuitry that would otherwise be needed to compute the position of the wireless terminal. When it is more advantageous that a remote facility know the location of the wireless terminal than that the wireless terminal know its own location, a Tidget system is advantageous in that it relays, in effect, the position of the wireless terminal to the remote facility.

FIG. 4 depicts a schematic diagram of a Tendler® satellite positioning system in the prior art. A wireless terminal constructed in accordance with this system comprises both the circuitry needed to determine its position from a satellite constellation and a wireless telephone transmitter to transmit the determined position to another party via a wireless telecommunications system.

Regardless of the advances made in satellite positioning systems, limitations still exist. Typically, the strength of the signals from the satellite constellation is too attenuated in buildings and other shadowed environments for a wireless terminal to receive. Furthermore, a wireless terminal can take several minutes to acquire the signals from the satellites it needs to determine its position.

SUMMARY OF THE INVENTION

Some embodiments of the present invention are capable of assisting a wireless terminal in determining its position based on signals transmitted from one or more navigation satellites. In particular, a wireless terminal that is assisted by an embodiment of the present invention can be less expensive than wireless terminals in the prior art. Furthermore, a wireless terminal that is assisted by an embodiment of the present invention is able to receive and use weaker signals than wireless terminals in the prior art; and still furthermore, a wireless terminal that is assisted by an embodiment of the present invention is capable of determining its location far more quickly than wireless terminals in the prior art.

An auxiliary system in accordance with an embodiment of the present invention assists a wireless terminal by apportioning the tasks of signal acquisition and signal processing that are normally borne by the wireless terminal alone between the wireless terminal and the auxiliary system. In particular, the requirements normally imposed on a wireless terminal in the prior art are off-loaded onto the auxiliary system that can provide useful information to the wireless terminal over a wireless telecommunications link.

It is possible to divide the signal acquisition and signal processing tasks between the wireless terminal and the auxiliary system because each signal transmitted by each satellite in a satellite positioning system's constellation carries two distinct kinds of information that are responsive to independent acquisition and independent processing. The two kinds of information are: (1) ranging information, and (2) information about the satellites' ephemerides.

The information about the satellites' ephemerides is the same for all receivers, regardless of their position. In contrast, the ranging information, which indicates to the receiver its distance from each satellite, is location dependent and can be received only by the wireless terminal itself. Therefore, the auxiliary system can assist the wireless terminal by acquiring the information about the satellites' ephemerides, by partially processing it and by transmitting it to the wireless terminal in a form that is useful to the wireless terminal. The auxiliary system cannot, however, acquire the ranging information for the wireless terminal.

By having the auxiliary system acquire the information about the satellites' ephemerides for the wireless terminal, the signal acquisition and signal processing demands of the wireless terminal are reduced. Furthermore, the wireless terminal can actually use the partially processed information from the auxiliary system to assist the wireless terminal in acquiring the ranging signals quickly and when they are weak.

When the wireless terminal is capable of providing the functionality of a wireless telecommunications terminal (e.g., a cellular telephone, a hand-held data entry device, etc.), the circuitry for determining the wireless terminal's location, in accordance with some embodiments of the present invention, can be added to the wireless terminal for moderately little cost.

BRIEF DESCRIPTION OF THE DRAWINGS

FIG. 1 is a block diagram of a satellite positioning system, such as GPS, in the prior art.

FIG. 2 is a block diagram of a differential GPS system in the prior art.

FIG. 3 is a block diagram a Tidget-like system in the prior art.

FIG. 4 is a block diagram of a Tendler-like system in the prior art.

FIG. 5 is a block diagram of a satellite positioning system in accordance with the illustrative embodiment of the present invention.

FIG. 6 is a block diagram of the auxiliary system shown in FIG. 5.

FIG. 7 is a block diagram of the wireless terminal shown in FIG. 5.

FIG. 8 is a block diagram of the field receiver shown in FIG. 7.

FIG. 9 is a flowchart of the operation of the auxiliary system and wireless terminal shown in FIG. 5 in accordance with one embodiment of the present invention.

FIG. 10 is a flowchart of the operation of the auxiliary system and wireless terminal shown in FIG. 5 in accordance with another embodiment of the present invention.

DETAILED DESCRIPTION

FIG. 5 depicts a drawing of a satellite positioning system in accordance with an illustrative embodiment of the present invention. The satellite positioning system depicted comprises wireless terminal 501, satellite constellation 503, auxiliary system 505 and timing source 507. Satellite constellation 503 is the Global Positioning System as is well-known in the art and will not be further discussed. It will be clear to those skilled in the art how to make and use embodiments of the present invention that work with other satellite constellations.

The principal goal of the illustrative embodiment is to reduce the signal acquisition and signal processing requirements of a conventional wireless terminal so that a wireless terminal in accordance with the illustrative embodiment can determine its location more quickly and with weaker signals than wireless terminals in the prior art. In accordance with the illustrative embodiment, the signal acquisition and signal processing requirements of wireless terminal 501 are reduced at the expense of auxiliary system 505. In particular, the tasks of signal acquisition and signal processing required for a conventional wireless terminal to determine its position are divided between wireless terminal 501 and auxiliary system 505.

It will be clear to those skilled in the art how the signal processing task can be divided between wireless terminal 501 and auxiliary system 505, as partially processed signal information can be exchanged back and forth between the two through wireless telecommunications link 504 as needed to achieve desirable division of the signal processing task.

It is possible to divide the signal processing task between wireless terminal 501 and auxiliary system 505 because each signal transmitted by each satellite in satellite constellation 503 carries two distinct kinds of information that are responsive to independent acquisition and independent processing. The two kinds of information are: (1) ranging information, and (2) information about the satellites' ephemerides. More specifically, the GPS signal is modulated with digital information in a manner similar to how, for example, a cellular telephone's radio signal is modulated with voice data. Such information can be detected and demodulated by any receiver adapted to do so. The information reconstructed by the receiver is an exact replica of the information modulated onto the signal by the transmitter (except for unwanted errors due to noise, distortion, etc.) and is the same for all receivers, regardless of their position. This information shall be referred to as "information about the satellites' ephemerides."

In contrast, in a location system there is also important information in the precise timing of the signal. The transmitter carefully adjusts the timing of the transmitted signal according to some precise reference, such that the timing of the signal, as received by the receiver, carries information about the distance between the transmitter and the receiver (and, therefore, about the receiver's position). Such information will be different from receiver to receiver, and is only available at the receiver itself. This information shall be referred to as "ranging information."

For example, since each satellite in constellation 503 transmits a signal 502 that contains both kinds of information to both wireless terminal 501 and auxiliary system 505, some or all of the information about the satellites' ephemerides is acquired by auxiliary system 505 through antenna 553, even though the ranging information acquired by auxiliary system 505 is relevant to the position of auxiliary system antenna 553 and not to the position of wireless terminal 501. However, auxiliary system 505 has approximate knowledge of the position of wireless terminal 501 (for example, through knowledge of the cell and sector where a mobile is located); therefore, auxiliary system 505 combines this knowledge with the acquired ranging information and with the satellites' ephemerides information to compute an estimate of the ranging information at the position of wireless terminal 501. This estimate, together with the satellites' ephemerides information, is transmitted, via wireless telecommunications antenna 551, to wireless terminal 501 to assist wireless terminal 501 in acquiring and processing ranging information.

Once the ranging information has been acquired by wireless terminal 501, wireless terminal 501 can use the satellite ephemeris information and ranging information to determine its location, or wireless terminal 501 can transmit the ranging information back to auxiliary system 505 so that auxiliary system 505 can determine the location of wireless terminal 501.

Because wireless terminal 501 is freed from the task of acquiring some or all of the information about the satellites' ephemerides and is advantageously provided with an estimate of the ranging information, it can be fabricated from

less expensive technology that need only perform the easier task of acquiring and processing the ranging information with a priori knowledge of an estimated form of that information. Furthermore, because the satellite ephemerides information is modulated onto the same carrier as the ranging information, the provision of the satellites' ephemerides information to wireless terminal **501** enables wireless terminal **501** to remove the satellites' ephemerides information from the satellite signal received through antenna **512** and, thereby, acquire the ranging information even under faded conditions of low signal-to-noise ratio that are inadequate for the operation of a wireless terminal in prior art.

Auxiliary system **505** can be a terrestrial facility, an airborne facility or an artificial satellite in orbit around the earth. Unlike a Differential Global Positioning System's terrestrial reference receiver, however, the position of auxiliary system **505** need not remain static nor need its exact location be known.

FIG. 6 depicts a block diagram of the salient components of auxiliary system **505**, which comprises: timing signal receiver **603**, timing signal antenna **552**, coarse location estimator **601**, telecommunications system manager **617**, GPS receiver **605**, GPS receiver antenna **553**, timing signal calibrator **607**, PRN synchronization estimator **609**, demodulator **611**, satellite visibility estimator **613**, satellite Doppler estimator **615**, telecommunications transmitter **619** and telecommunications antenna **551**.

In general, auxiliary system **505** uses its GPS receiver to obtain from each satellite above the horizon both ranging information and information about the satellite's ephemeris, in wellknown fashion using the C/A or Coarse Acquisition code. It will be clear to those skilled in the art how to make and use embodiments of the present invention that use the P(Y) or P code. In the process of obtaining the ranging and satellite ephemeris information, auxiliary system **505** learns, among other things: (1) the PRN synchronization from each satellite (i.e., the exact timing of the PRN code transmitted by each satellite), (2) the Doppler shift associated with each satellite, (3) which satellites are above the horizon, and (4) the 50 bps modulated bit stream from each satellite. Auxiliary system **505** then transmits to wireless terminal **501**, via a wireless telecommunications channel, for each satellite above the horizon: (1) an estimate of the PRN synchronization, (2) an estimate of the Doppler shift, and (3) the 50 bps modulated bit stream. Collectively, this information will be called "Navigation Message Data."

When auxiliary system **505** is part of a wireless telecommunications system that partitions a geographic area into a number of tessellated areas called "cells," auxiliary system **505** knows which cell wireless terminal **501** is in and, therefore, its rough location to within a few miles. When auxiliary system **505** has a rough idea (e.g., within a few miles) of the position of wireless terminal **501**, auxiliary system **505** can accurately estimate the PRN synchronization and Doppler shift as seen by wireless terminal **501**.

Because the PRN synchronization estimate, the Doppler shift estimate and the 50 bps modulated bitstream are perishable and only useful when wireless terminal **501** and auxiliary system **505** are synchronized within a few GPS C/A code chips, both wireless terminal **501** and auxiliary system **505** are advantageously synchronized to within 1 μ s. To accomplish this, both wireless terminal **501** and auxiliary system **505** can receive a timing synchronization signal from independent timing source **507**, in well-known fashion. Alternatively, auxiliary system **505** can contain a timing

source and can transmit a synchronization signal to wireless terminal **501** over the telecommunications channel.

For example, when auxiliary system **505** is part of a CDMA wireless telecommunications system and wireless terminal **501** is CDMA compliant, both auxiliary system **505** and wireless terminal **501** will be synchronized to within 1 μ s and timing source **507** is not needed. It will be clear to those skilled in the art how to provide synchronization for wireless terminal **501** and auxiliary system **505**.

Returning to FIG. 6, when auxiliary system **505** is part of an IS-95 CDMA telecommunications system, telecommunications system manager **617** informs coarse location estimator **601** of the cell in which wireless terminal **501** is located. Furthermore, telecommunications system manager **617** can instigate the process of locating wireless terminal **501** when, for example, wireless terminal **501** is carried by a lost child. As another example, a "911" emergency-services call from wireless terminal **501** can provoke telecommunications system manager **617** to locate wireless terminal **501** and direct emergency service personnel to the location of wireless terminal **501**. Another position-based service could enable a person whose car had broken down to enter a code, such as *TOW, into wireless terminal **501**. Wireless terminal **501** would then relay *TOW to telecommunications system manager **617**, which would then ascertain the position of wireless terminal **501** and establish a call between wireless terminal **501** and the towing service that was closest to wireless terminal **501**. The disclosure of pending U.S. patent application Ser. No. 08/784108, filed Jan. 15, 1997, entitled "Wireless Location Messaging," is incorporated by reference.

Coarse location estimator **601** uses the information from telecommunications system manager **617** to produce an estimate of the latitude and longitude of the location of wireless terminal **501**, which estimate could simply be the location of the center of the cell or sector containing wireless terminal **501**.

Timing signal receiver **603** receives the same timing signal from timing source **507** that is received by wireless terminal **501**, when timing source **507** is needed for synchronization. The locations of timing signal receiver **603** and timing source **507** must be known with sufficient accuracy to allow timing signal calibrator **607** to accurately determine the timing signal delay between timing source **507** and timing signal receiver **603**, as well as the timing signal delay between timing source **507** and wireless terminal **501**. For example, the required timing accuracy could be 1 μ sec, based on the coarse estimate of the location of wireless terminal **501**. Alternatively, timing signal receiver **603** could receive the timing signal from GPS constellation **503**.

GPS receiver **605** receives a signal, via GPS receiver antenna **553**, from each satellite in satellite constellation **503** above the horizon and determines each signal's exact time of arrival (i.e., its PRN synchronization). Demodulator **611** demodulates each acquired signal to recover its 50 bps modulated bit stream. PRN synchronization estimator **609** predicts the exact time of arrival of each C/A code signal from each visible satellite at wireless terminal **501** and uses these predictions to estimate the PRN sequence timing to be used by the field receiver in wireless terminal **501** for proper de-spreading of the respective C/A code signals. It should be understood that although PRN synchronization estimator **609** cannot determine the exact PRN sequence timing at wireless terminal **501**, a good estimate (e.g., one that is correct within 10 or 20 chips) substantially reduces the number of trial PRN synchronizations that wireless terminal **501** would otherwise have to try.

Satellite visibility estimator **613** extracts the satellite ephemeris from the received modulation bit streams and estimates which satellites are visible to wireless terminal **501** at its location. Similarly, satellite Doppler estimator **615** extracts satellite ephemeris information from the received modulation bit streams and estimates which satellites are visible to wireless terminal **501** at its location. Telecommunications transmitter **619** takes the satellite visibility estimate, the PRN synchronization estimate for each satellite, the Doppler shift estimate for each satellite and the 50 bps modulated bitstream for each satellite and transmits to wireless terminal **501** over a telecommunications channel for each satellite above the horizon: (1) an estimate of the PRN synchronization, (2) an estimate of the Doppler shift, and (3) the 50 bps modulated bit stream. It will be clear to those skilled in the art how to make and use auxiliary system **505**.

FIG. 7 depicts a block diagram of the major components of wireless terminal **501**, which comprises: terminal controller **710**, user interface **720**, telecommunications transmitter **741**, telecommunications receiver **751**, field receiver **753**, timing receiver **755**, duplexer **733** and antenna **731**, interconnected as shown.

Advantageously, but not necessarily, wireless terminal **501** is capable of performing all of the functionality associated with a typical wireless terminal particular a user telephone. In particular a user of wireless terminal is advantageously capable of having a two-way voice conversation through telecommunications transmitter **741**, telecommunications receiver **751** and auxiliary system **505**.

Because the Navigation Message Data is transmitted to wireless terminal **501** from auxiliary system **505**, the Navigation Message Data is received by wireless terminal **501** via telecommunications receiver **751**. Telecommunications receiver **751** passes the Navigation Message Data to terminal controller **710**, which, in turn, passes the Navigation Message Data to field receiver **753**.

As discussed above, wireless terminal **501** also advantageously receives system timing for synchronization purposes. When the timing signal is transmitted from timing source **507**, the timing signal is received by wireless terminal **501** via timing receiver **755**. Timing receiver **755** passes the timing signal to terminal controller **710** which, in turn, passes the timing signal to field receiver **753**. Alternatively, when the timing signal is transmitted from auxiliary system **505**, (as is the case when wireless terminal **501** and auxiliary system **505** are part of a CDMA telecommunications system) the timing signal is received by telecommunications receiver **751**. Telecommunications receiver **751** then passes the timing signal to terminal controller **710** which, in turn, passes the timing signal to field receiver **753**.

In either case, field receiver **753** receives the timing information that it needs without needing to derive it from satellite constellation **503**. Furthermore, field receiver **753** also receives for each satellite above the horizon: (1) an estimate of the PRN synchronization, (2) an estimate of the Doppler shift, and (3) the 50 bps modulated bit stream, again without having received any of this information directly from satellite constellation **503**.

Wireless terminal **501** also advantageously receives the direct sequence spread spectrum C/A code signals from satellite constellation **503** via field receiver **753**.

FIG. 8 depicts a block diagram of the major components of field receiver **753** that process the C/A code signal from one satellite in satellite constellation **503**. For pedagogical reasons, the functions of field receiver **753** are depicted in FIG. 8 as separate functional blocks that operate on one C/A

code signal. It will be clear to those skilled in the art that in many embodiments of the present invention field receiver **753** will be an appropriately programmed general-purpose microprocessor or digital signal processor that simultaneously operates on C/A code signals from multiple satellites. It will also be clear to those skilled in the art that many of the functional blocks in FIG. 8 can be substituted for by transform techniques.

In FIG. 8, SPS controller **821** advantageously receives the Navigation Message Data and timing synchronization information from lead **761** and outputs: (1) the PRN synchronization estimate to PRN code generator **819**, (2) the Doppler shift estimate to Doppler correction **809**, and the 50 bps modulation bit stream to mixer **815** and location computer **823**, all appropriately synchronized. RF front end **801** receives the C/A code signal from a satellite, filters out everything other than the band of interest and mixes it down to IF in well known fashion. A/D converter **803** takes the mixed-down signal and samples it at twice the chipping rate of 1.023 MChips/sec. or more. PRN code generator **819** begins generating the PRN code sequence at 1.023 MChips/sec., which PRN code sequence has a period of 1023 chips, as is well-known in the art. PRN code generator **819** can also use the Doppler shift estimate to correct the PRN code sequence chip rate for Doppler shift, but, because the Doppler shift on the PRN code sequence is usually very small, this need not always be done. It will be clear to those skilled in the art when PRN code generator **819** can neglect correcting for Doppler shift and when it can not.

It will be understood by those skilled in the art how the signal processing functions performed by the blocks that follow A/D converter **803** in FIG. 8 can also be performed in alternative embodiments using analog techniques. In such embodiments, field receiver **753** will be described by a block diagram similar to the one of FIG. 8 except that AID converter **803** will appear at a different point in the functional sequence of blocks.

It should be understood that no guarantee is needed that the PRN synchronization estimate be correct or that the first PRN code sequence from PRN code generator **819** be synchronized exactly. If it turns out that the PRN code sequence from PRN code generator **819** is not synchronized (as is determined by spectral analyzer **817**), the PRN code generator **819** will use the PRN synchronization estimate as an educated guess at finding the true synchronization through a progressive search of synchronization positions near the estimate, in well-known fashion.

Mixer **805** multiplies the PRN code sequence and the digitized C/A code signal and outputs the despread C/A code to lowpass filter **807**. Lowpass filter **807** advantageously reduces the bandwidth of the signal so that it can be sampled at a lower rate. This allows Doppler correction block **809** to ignore all but one out of every several samples it receives from lowpass filter **807**, so that the resulting number of samples per second is at least the Nyquist rate needed for accurate representation of the output of lowpass filter **807**, or twice the bandwidth occupied by the output of lowpass filter **807**. Advantageously, the bandwidth is equal to the largest Doppler shift observable in the signal (caused by the relative motion of the satellite with respect to wireless terminal **501**) increased by the bandwidth occupied by the 50-bps signal itself. For example, the bandwidth occupied by the output of Lowpass filter **807** can be 8 kHz, corresponding to a Nyquist rate of 16 kilosamples/s).

The Doppler shift caused by the relative motion of the satellite with respect to wireless terminal **501** is comprised of two components: a Doppler shift caused by the relative motion of the satellite with respect to ground (for which an estimate is included in the navigation message data) and a

Doppler shift caused by the relative motion, if any, of wireless terminal **501** with respect to ground. Doppler correction **809** takes the signal from lowpass filter **807** and corrects for the estimated Doppler shift due to the relative motion of the satellite with respect to ground. This can be accomplished, in well-known fashion, through, for example, frequency conversion techniques where the frequency of a local oscillator is adjusted to achieve the desired correction.

The output of Doppler correction **809** is fed into lowpass filter **811** which advantageously further reduces the bandwidth of the signal so that it can be sampled at a yet lower rate. Again, FIFO **813** can ignore all but one out of every several samples it receives from lowpass filter **811**. The samples that are not ignored must occur at a rate that is at least a Nyquist rate equal to twice the bandwidth occupied by the output of lowpass filter **811**. Advantageously, the bandwidth is equal to the largest Doppler shift caused by the relative motion of wireless terminal **501** with respect to ground increased by the bandwidth occupied by the 50-bps signal itself. For example, the bandwidth occupied by the output of lowpass filter **811** can be 500 Hz, corresponding to a Nyquist rate of 1 kilosamples/s).

The output of lowpass filter **811** is fed into FIFO memory **813**, which delays the signal for only so long as it takes auxiliary system **505** to recover the 50 bps modulated bit stream and forward it to SPS controller **821**. Typically, FIFO memory **813** need only delay the signal for, most, a few seconds. The output of FIFO memory **813** is fed into mixer **815** to be mixed with the carefully synchronized 50 bps modulated bit stream. The mixing operation will further despread the signal by removing the 50-bps modulation. As a result, the output of mixer **815** will be the unmodulated signal carrier, if a signal is present (i.e., if the PRN synchronization is correct).

The output of mixer **813** is fed into spectral analyzer **817**, which performs, for example, a discrete fourier transform in well-known fashion. When the output of mixer **813** is a pure sinusoid (which is indicated by a spectral spike out of spectral analyzer **817**), it means that PRN code generator **819** is perfectly in sync with the C/A code signal from the satellite. When the output of mixer **813** is other than a pure sinusoid (which is indicated by something other than a spectral spike out of spectral analyzer **817**), it means that PRN code generator **819** is not in sync with the C/A code signal and must try another synchronization. It will be clear to those skilled in the art how to perform the spectral analysis through techniques different than those described here, however, that yield the same result, which is detecting the presence or absence of a narrowband component in the output of mixer **815**.

Importantly, when PRN code generator is in sync with the C/A code signal from the satellite, it means that location computer **823** can compute the ranging information (i.e., how long did it take the signal to travel from the satellite to wireless terminal **501**). And because location computer **823** knows: (1) the PRN code synchronization from PRN code generator **819**, (2) the modulated bit stream from SPS controller **821** and (3) when the PRN code is synchronized from spectral analyzer **817**, location computer **823** can compute the location of wireless terminal **501**, in well-known fashion.

The location of wireless terminal **501** can then be output from location computer **823** to terminal controller **710** and to telecommunications transmitter **741** for transmission back to auxiliary system **505** over a telecommunications channel. Auxiliary system **505** can then use the location of wireless terminal **501** in any number of location-based services.

FIG. 9 is a flowchart of the operation of the auxiliary system and wireless terminal shown in FIG. 5 in accordance with one embodiment of the present invention.

FIG. 10 is a flowchart of the operation of the auxiliary system and wireless terminal shown in FIG. 5 in accordance with another embodiment of the present invention.

What is claimed is:

1. An auxiliary system comprising:

a satellite positioning system receiver for receiving a signal from a satellite;

a PRN code synchronization estimator for generating a PRN code synchronization estimate based on said signal; and

a telecommunications transmitter for transmitting said PRN code synchronization estimate to a wireless terminal over a wireless telecommunications link.

2. The auxiliary system of claim 1 further comprising a Doppler shift estimator for generating a Doppler shift estimate, and wherein said telecommunications transmitter at its said Doppler shift estimate to said wireless terminal.

3. The auxiliary system of claim 1 further comprising a demodulator for generating a modulation bit sequence, and wherein said telecommunications transmitter also transmits said modulation bit sequence to said wireless terminal.

4. The auxiliary system of claim 1 further comprising a timing signal receiver for generating a system timing signal, wherein said telecommunications transmitter also transmits said system timing signal to said wireless terminal.

5. The auxiliary system of claim 1 further comprising a coarse location estimator for generating a coarse location estimate of said wireless terminal and wherein said PRN code synchronization estimate is based on said signal and said coarse location estimate.

6. The auxiliary system of claim 1 further comprising:

a receiver for receiving a partially processed ranging signal from said wireless terminal; and

means for determining a location of said wireless terminal based on said partially processed ranging signal.

7. The auxiliary system of claim 1 further comprising a receiver for receiving a location of said wireless terminal from said wireless terminal.

8. The auxiliary system of claim 7 further comprising means for using said location of said wireless terminal in a location-based service.

9. An auxiliary system comprising:

a satellite positioning system receiver for receiving a signal from a satellite;

a demodulator for generating a modulation bit sequence based on said signal; and

a telecommunications transmitter for transmitting said modulation bit sequence to a wireless terminal over a wireless telecommunications link.

10. The auxiliary system of claim 9 further comprising a Doppler shift estimator for generating a Doppler shift estimate, and wherein said telecommunications transmitter also transmits said Doppler shift estimate to said wireless terminal.

11. The auxiliary system of claim 9 further comprising a PRN code synchronization estimator for generating a PRN code synchronization estimate, and wherein said telecommunications transmitter also transmits said PRN code synchronization estimate to said wireless terminal.

12. The auxiliary system of claim 9 further comprising a timing signal receiver for generating a system timing signal, wherein said telecommunications transmitter also transmits said system timing signal to said wireless terminal.

13. The auxiliary system of claim 11 further comprising a coarse location estimator for generating a coarse location estimate of said wireless terminal and wherein said PRN code synchronization estimate is based on said signal and said coarse location estimate.

11

14. The auxiliary system of claim 9 further comprising:
 a receiver for receiving a partially processed ranging
 signal from said wireless terminal; and
 means for determining a location of said wireless terminal
 based on said partially processed ranging signal. 5

15. The auxiliary system of claim 9 further comprising a
 receiver for receiving a location of said wireless terminal
 from said wireless terminal.

16. The auxiliary system of claim 15 further comprising
 means for using said location of said wireless terminal in a
 location-based service. 10

17. An auxiliary system comprising:
 a timing signal receiver for generating a system timing
 signal;
 a satellite positioning system receiver for receiving a
 signal from a satellite; 15
 a demodulator for generating a modulation bit sequence;
 and
 a telecommunications transmitter for transmitting said
 system timing signal and said modulation bit sequence
 to a wireless terminal over a wireless telecommunica-
 tions link. 20

18. An auxiliary system comprising:
 a timing signal receiver for generating a system timing
 signal; 25
 a satellite positioning system receiver for receiving a
 signal from a satellite;
 a PRN code synchronization estimator for generating a
 PRN code synchronization estimate based on said
 signal; and 30
 a telecommunications transmitter for transmitting said
 system timing signal and said PRN code synchroniza-
 tion estimate to a wireless terminal over a wireless
 telecommunications link.

19. The auxiliary system of claim 18 further comprising
 a coarse location estimator for generating a coarse location
 estimate of said wireless terminal and wherein said PRN
 code synchronization estimate is based on said signal and
 said coarse location estimate. 35

20. An auxiliary system comprising:
 a satellite positioning system receiver for receiving a
 signal from a satellite; 40
 a Doppler shift estimator for generating a Doppler shift
 estimate based on said signal;
 a PRN code synchronization estimator for generating a
 PRN code synchronization estimate 45
 a telecommunications transmitter for transmitting said
 Doppler shift estimate and said PRN code synchroni-
 zation estimate to a wireless terminal over a wireless
 telecommunications link.

21. An auxiliary system comprising: 50
 a satellite positioning system receiver for receiving a
 signal from a satellite;
 a Doppler shift estimator for generating a Doppler shift
 estimate based on said signal;
 a demodulator for generating a modulation bit sequence 55
 a telecommunications transmitter for transmitting said
 Doppler shift estimate and said modulation bit
 sequence to a wireless terminal over a wireless tele-
 communications link.

22. The auxiliary system of claim 20 further comprising
 a coarse location estimator for generating a coarse location
 estimate of said wireless terminal and wherein said PRN
 code synchronization estimate is based on said signal and
 said coarse location estimate. 60

23. A method comprising: 65
 receiving a signal from a satellite with a satellite posi-
 tioning system receiver;

12

generating a PRN code synchronization estimate based on
 said signal with a PRN code synchronization estimator;
 and
 transmitting said PRN code synchronization estimate to a
 wireless terminal over a wireless telecommunications
 link.

24. The method of claim 23 further comprising:
 generating a Doppler shift estimate with a Doppler shift
 estimator; and
 transmitting said Doppler shift estimate to said wireless
 terminal.

25. The method of claim 23 further comprising:
 generating a modulation bit sequence with a demodulator;
 and
 transmitting said modulation bit sequence to said wireless
 terminal.

26. The method of claim 23 further comprising:
 generating a system timing signal with a timing signal
 receiver; and
 transmitting said system timing signal to said wireless
 terminal.

27. The method of claim 23 further comprising generating
 a coarse location estimate of said wireless terminal with a
 coarse location estimator, and wherein said PRN code
 synchronization estimate is based on said signal and said
 coarse location estimate.

28. The method of claim 23 further comprising:
 receiving a partially processed ranging signal from said
 wireless terminal; and
 determining a location of said wireless terminal based on
 said partially processed ranging signal.

29. The method of claim 23 further comprising receiving
 a location of said wireless terminal from said wireless
 terminal.

30. The method of claim 29 further comprising means for
 using said location of said wireless terminal in a location-
 based service.

31. A method comprising:
 receiving a signal from a satellite with a satellite posi-
 tioning system receiver;
 generating a modulation bit sequence based on said signal
 with a demodulator; and
 transmitting said modulation bit sequence to a wireless
 terminal over a wireless telecommunications link.

32. The method of claim 31 further comprising:
 generating a Doppler shift estimate with a Doppler shift
 estimator; and
 transmitting said Doppler shift estimate to said wireless
 terminal.

33. The method of claim 31 further comprising:
 generating a PRN code synchronization estimate with a
 PRN code synchronization estimator; and
 transmitting said PRN code synchronization estimate to
 said wireless terminal.

34. The method of claim 31 further comprising:
 generating a system timing signal with a timing signal
 receiver; and
 transmitting said system timing signal to said wireless
 terminal.

35. The method of claim 33 further comprising generating
 a coarse location estimate of said wireless terminal with a
 coarse location estimator, and wherein said PRN code
 synchronization estimate is based on said signal and said
 coarse location estimate.

36. The method of claim 31 further comprising:
 receiving a partially processed ranging signal from said
 wireless terminal; and

13

determining a location of said wireless terminal based on said partially processed ranging signal.

37. The method of claim 31 further comprising receiving a location of said wireless terminal from said wireless terminal.

38. The method of claim 37 further comprising using said location of said wireless terminal in a location-based service.

39. A method comprising:

generating a system timing signal with a timing signal receiver;

receiving a signal from a satellite with a satellite positioning system receiver;

generating a modulation bit sequence based on said signal with a demodulator; and

transmitting said timing signal receiver and said modulation bit sequence to said wireless terminal.

40. A method comprising:

generating a system timing signal with a timing signal receiver;

receiving a signal from a satellite with a satellite positioning system receiver;

generating a PRN code synchronization estimate based on said signal with a PRN code synchronization estimator; and

transmitting said timing signal receiver and said PRN code synchronization estimate to said wireless terminal.

41. The method of claim 40 further comprising generating a coarse location estimate of said wireless terminal with a coarse location estimator, and wherein said PRN code synchronization estimate is based on said signal and said coarse location estimate.

42. A method comprising:

receiving a signal from a satellite with a satellite positioning system receiver;

generating a Doppler shift estimate based on said signal with a Doppler shift estimator;

generating a PRN code synchronization estimate with a PRN code synchronization estimator; and

transmitting said Doppler shift estimate and said PRN code synchronization estimate to said wireless terminal.

43. A method comprising:

receiving a signal from a satellite with a satellite positioning system receiver;

generating a Doppler shift estimate based on said signal with a Doppler shift estimator;

generating a modulation bit sequence with a demodulator; and

transmitting said Doppler shift estimate and said modulation bit sequence to said wireless terminal.

44. The method of claim 42 further comprising generating a coarse location estimate of said wireless terminal with a coarse location estimator, and wherein said PRN code synchronization estimate is based on said signal and said coarse location estimate.

45. An auxiliary system comprising:

a coarse location estimator for generating a coarse location estimate of a wireless terminal;

a PRN code synchronization estimator for generating a PRN code synchronization estimate based on said coarse location estimate; and

a telecommunications transmitter for transmitting said PRN code synchronization estimate to a wireless terminal over a wireless telecommunications link.

46. The auxiliary system of claim 45 further comprising a Doppler shift estimator for generating a Doppler shift

14

estimate based on said coarse location estimate, and wherein said telecommunications transmitter also transmits said Doppler shift estimate to said wireless terminal.

47. The auxiliary system of claim 45 further comprising a demodulator for generating a modulation bit sequence, and wherein said telecommunications transmitter also transmits said modulation bit sequence to said wireless terminal.

48. The auxiliary system of claim 45 further comprising a timing signal receiver for generating a system timing signal, wherein said telecommunications transmitter also transmits said system timing signal to said wireless terminal.

49. The auxiliary system of claim 45 further comprising a satellite positioning system receiver for receiving a signal from a satellite, and wherein said PRN code synchronization estimate is based on said signal and said coarse location estimate.

50. The auxiliary system of claim 45 further comprising: a receiver for receiving a partially processed ranging signal from said wireless terminal; and means for determining a location of said wireless terminal based on said partially processed ranging signal.

51. The auxiliary system of claim 45 further comprising a receiver for receiving a location of said wireless terminal from said wireless terminal.

52. The auxiliary system of claim 51 further comprising means for using said location of said wireless terminal in a location-based service.

53. A method comprising:

generating a coarse location estimate of said wireless terminal with a coarse location estimator;

generating a PRN code synchronization estimate based on said coarse location estimate with a PRN code synchronization estimator; and

transmitting said PRN code synchronization estimate to a wireless terminal over a wireless telecommunications link.

54. The method of claim 53 further comprising:

generating a Doppler shift estimate based on said coarse location estimate with a Doppler shift estimator; and transmitting said Doppler shift estimate to a wireless terminal over a wireless telecommunications link.

55. The method of claim 53 further comprising:

generating a modulation bit sequence with a demodulator; and

transmitting said modulation bit sequence to said wireless terminal.

56. The method of claim 52 further comprising:

generating a system timing signal with a timing signal receiver; and

transmitting said system timing signal to said wireless terminal.

57. The method of claim 53 further comprising

receiving a signal from a satellite with a satellite positioning system receiver, and wherein said PRN code synchronization estimate is based on said signal and said coarse location estimate.

58. The method of claim 53 further comprising:

receiving a partially processed ranging signal from said wireless terminal; and

determining a location of said wireless terminal based on said partially processed ranging signal.

59. The method of claim 53 further comprising receiving a location of said wireless terminal from said wireless terminal.

60. The method of claim 59 further comprising means for using said location of said wireless terminal in a location-based service.